



## BIL

### Construction

Belt driven type, double flanged casing, is produced in mild steel or galvanised steel with backward curve wheels.

### Finish

Painting or galvanised after manufacture are normal finishes on all parts.

### Operating Temperature

-20°C to +85°C

### Motors

Totally enclosed Class 'F' motor, to a min. IP54 protection are fitted as standard. Standard motor up to 2.2kW are usually supplied on DOL starting, motor 3.0kW and above are star/delta starting.

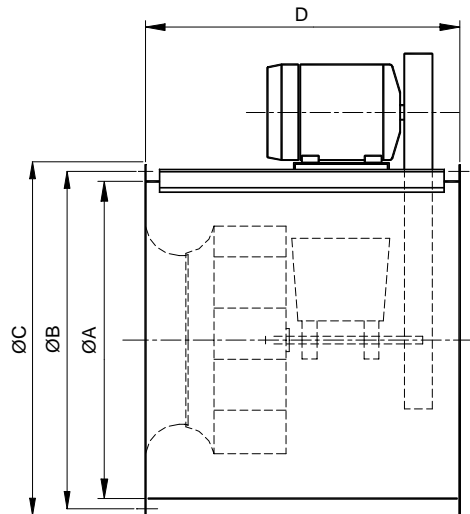
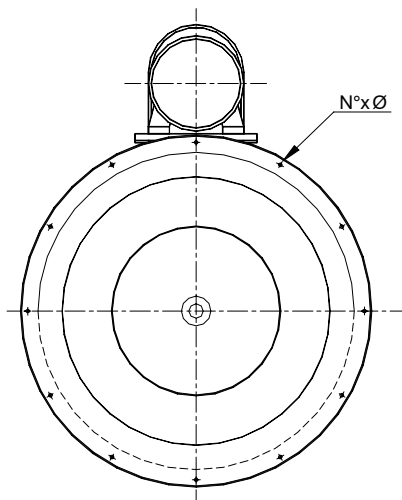

All Dimension in mm.

MODEL	A	B	C	D	N°	Ø
250	315	355	395	503	8	10
280	355	395	435	530	8	10
315	400	440	480	560	12	10
355	450	490	530	595	12	10
400	500	540	580	674	12	10
450	560	605	660	750	12	10
500	630	675	730	795	12	10
560	710	755	810	852	18	12

MODEL	A	B	C	D	N°	Ø
630	800	845	900	912	18	12
710	900	945	1000	978	18	12
800	1000	1050	1100	1036	24	12
900	1120	1185	1250	1295	24	12
1000	1250	1315	1380	1410	24	12
1120	1400	1465	1530	1620	32	14
1250	1600	1663	1730	1770	32	14
1400	1800	1856	1930	1930	32	14