



TDA - M CASED

Construction

Cheaper construction with shorter double flanged casing, is produced in mild steel or galvanised steel, the impeller having manually adjustable pitch blades is made of PPG, PAG or pressure-casted Aluminium.

Finish

Painting or galvanised after manufacture are normal finishes on all parts.

Operating Temperature

-20°C to +55°C

Motors

Totally enclosed Class 'F' motor, to a min. IP54 protection are fitted as standard. Standard motor up to 2.2kW are usually supplied on DOL starting, motor 3.0kW and above are star/delta starting.

Airflow Direction

Air flowing from impeller to motor are fitted as standard. Air flowing from motor to impeller can be supplied on request.

Option

Spark resistance construction in accordance to AMCA standard 99-0401-86 type C construction can be supplied upon request.

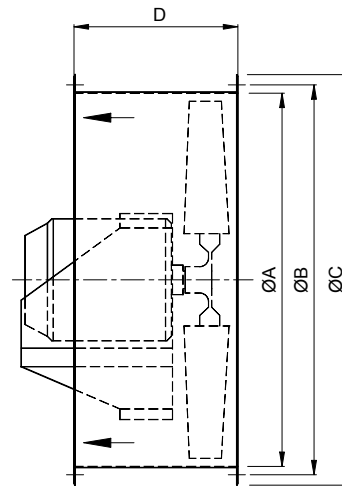
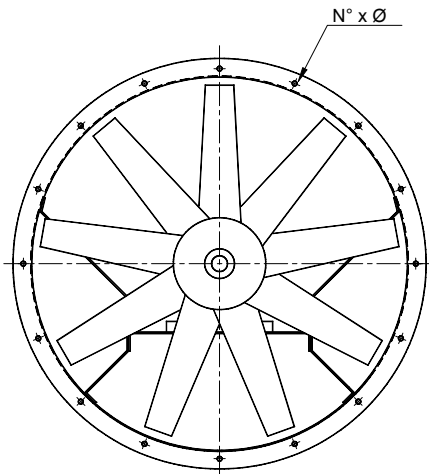

All Dimension in mm.

MODEL	A	B	C	D	N°	Ø	Weight (kg)	Max.Motor* FrameSize
315	315	355	395	200	8	10	6	D71
355	355	395	435	200	8	10	7	D80
400	400	440	480	235	12	10	7.5	D90S
450	450	490	530	255	12	10	8	D90L
500	500	540	580	285	12	10	11	D90L
560	560	605	660	346	12	10	16	D112M
630	630	675	730	346	12	10	18	D112M

MODEL	A	B	C	D	N°	Ø	Weight (kg)	Max.Motor* FrameSize
710	710	755	810	406	18	12	30	D112M
800	800	845	900	406	18	12	40	D132M
900	900	945	1000	495	18	12	51	D160M
1000	1000	1050	1100	550	24	12	57	D160M
1120	1120	1185	1250	650	24	12	96	D225M
1250	1250	1315	1380	700	24	12	147	D250M
1400	1400	1465	1530	770	32	14	171	D250M

* Motor frame size beyond this range, please consult KRUGER for details --- Weight without motor and impeller.

2 POLES - 2800 RPM

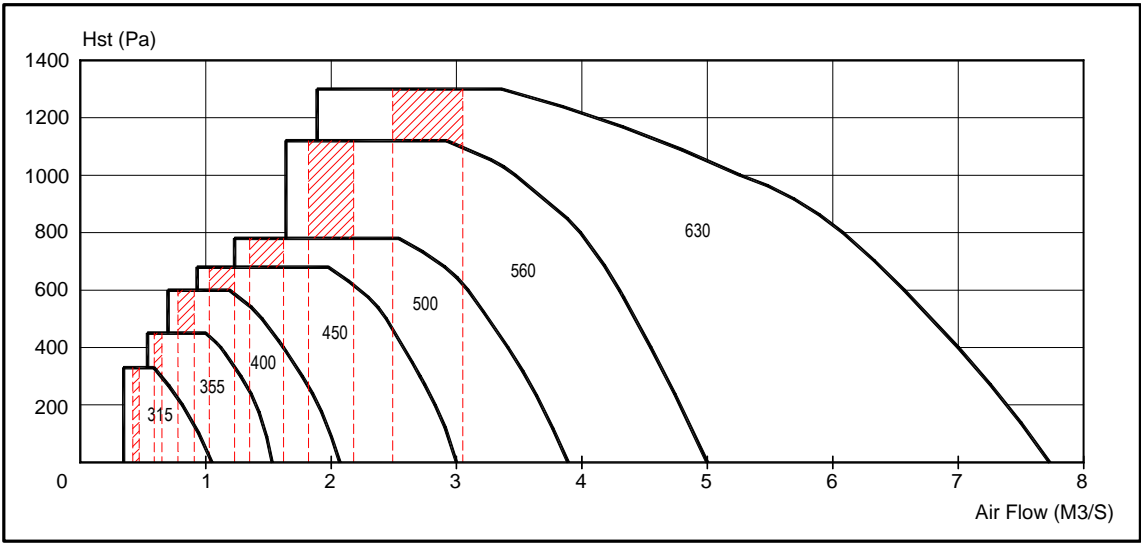

4 POLES - 1420 RPM

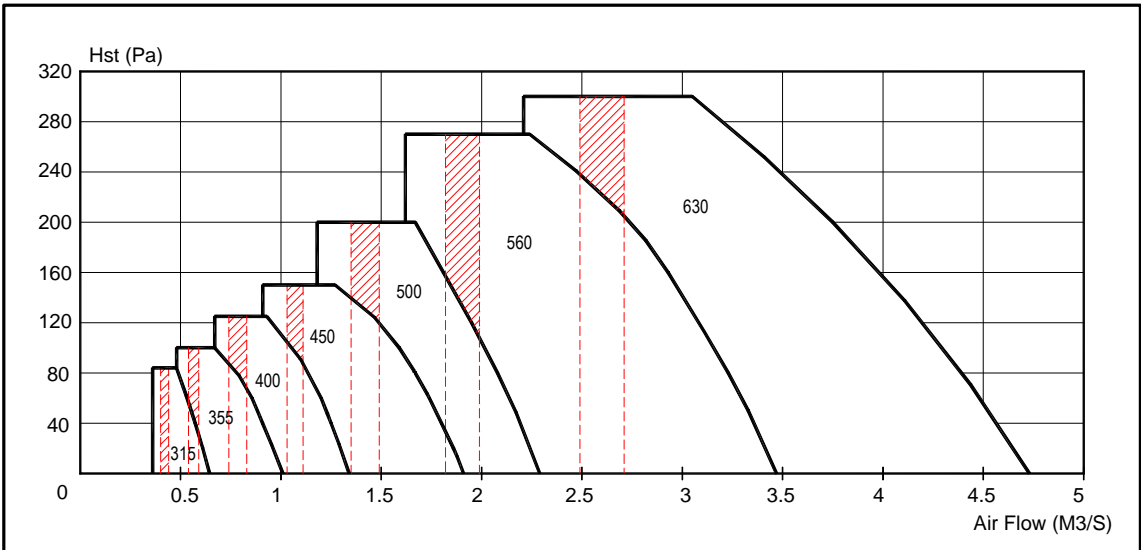

4 POLES - 1420 RPM

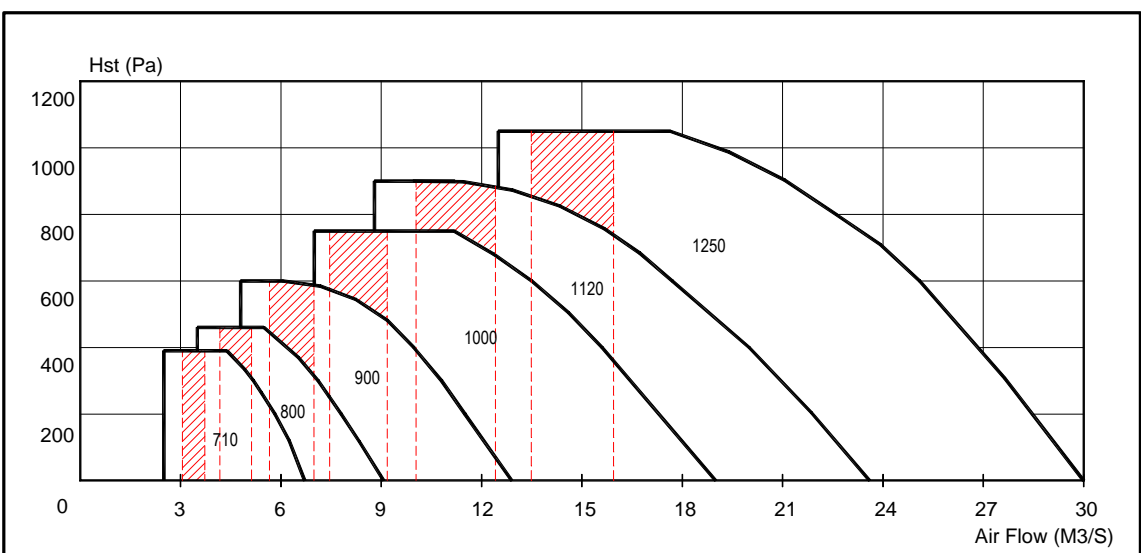

*** Shaded portion is the recommended operating range based on the duct velocity consideration (friction loss of 1 Pa/m)

6 POLES - 900 RPM

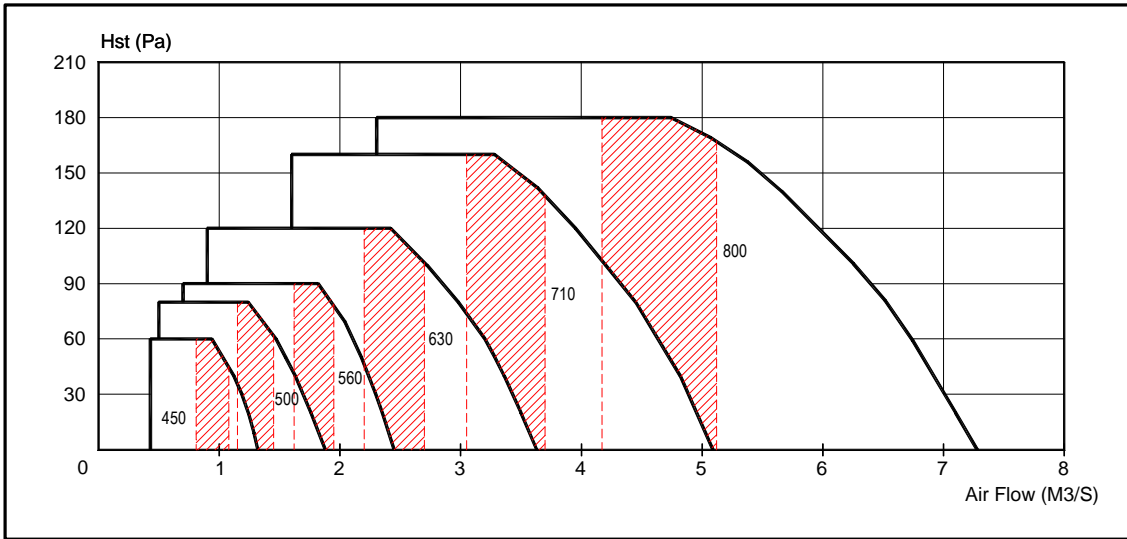

6 POLES - 900 RPM

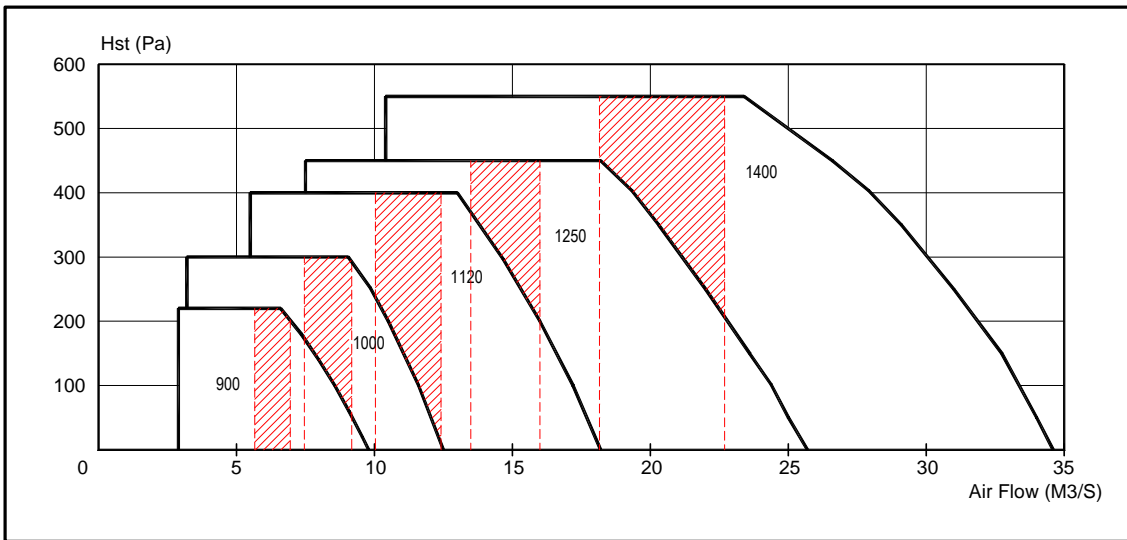

8 POLES - 720 RPM

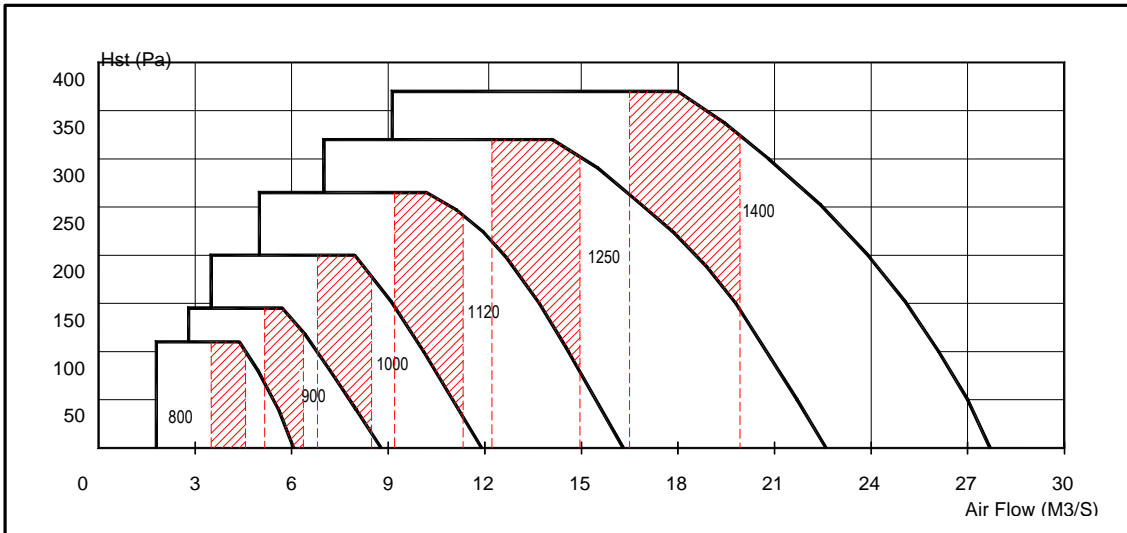

*** Shaded portion is the recommended operating range based on the duct velocity consideration (friction loss of 1 Pa/m)

4 POLES - 1750 RPM

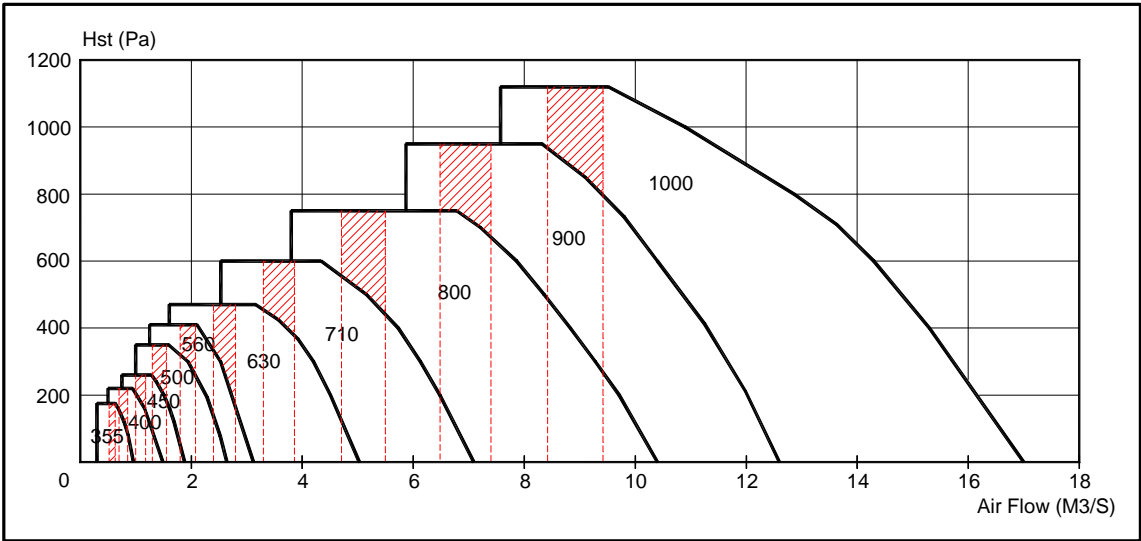

6 POLES - 1150 RPM

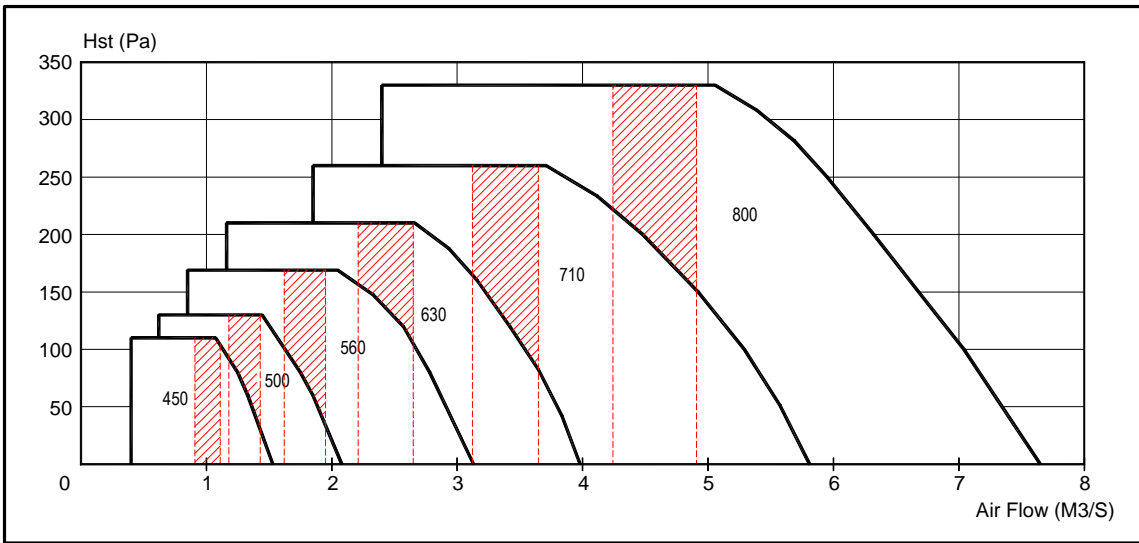

6 POLES - 1150 RPM

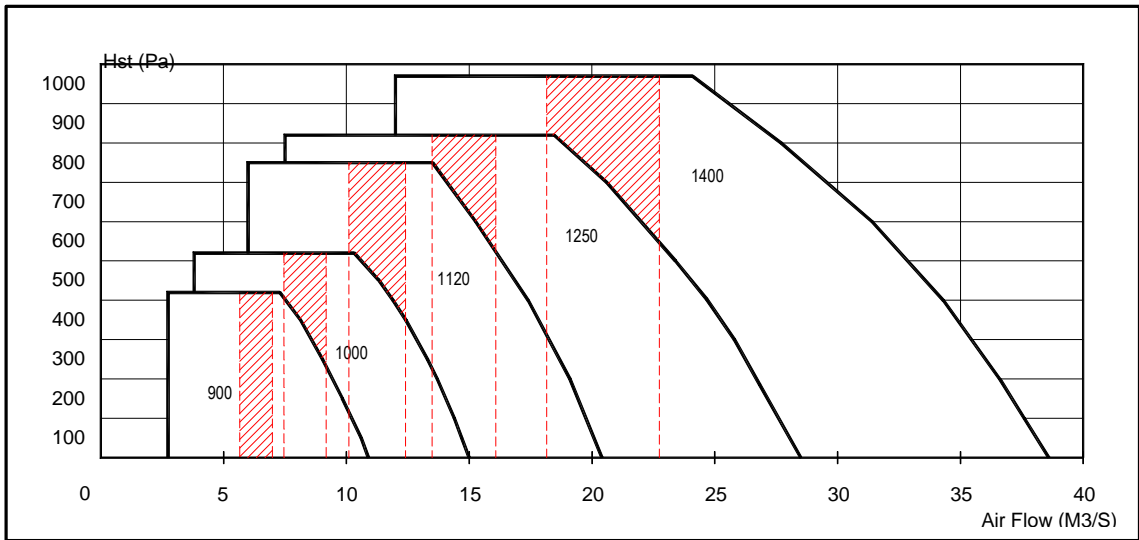

*** Shaded portion is the recommended operating range based on the duct velocity consideration (friction loss of 1 Pa/m)